

One of the largest wood protection facilities in Europe.

Bitus is one of Europe's largest wood preservation facilities. It is also one of the most environmentally friendly.

The Bitus wood protection facility in Nybro offers traditional wood protection treatment in several different standards. Bitus is the sole producer of Linax, double wood preservative-treated timber. Bitus is also producing Fire Retardant and Thermo-heat treated timber products.

Bitus stocks a large standard range of products for distribution in Europe and customisation is possible.

Contact us with your enquiry or visit our website to see our full range!

WWW.BITUS.COM



Why Linax?

- Highly suitable for extreme climate conditions
- Long maintenance intervals
- Ready for immediate installation
- Dimensionally stable
- Designed to repel moisture
- Environmentally rated with unique low emissions of copper
- 50 years anti-rot guarantee*
- 12-year product warranty*
- Certified raw material

Linax Natural.

* for the full guarantee, visit www.bitus.com

Assembly & Maintenance

- Linax is only for outdoor and above-ground use.
- Decking boards must be installed with a gap of approx 4 mm to allow air flow.
- All fasteners must be stainless steel or acid-resistant in severe climates.
- Use painted plates etc. or stainless steel material. This is to prevent discolouration of materials.
- All cut surfaces/sections should be coated with Linax Linseed Oil Glaze Brown, Linseed Oil Glaze Natural or Linseed Oil Glaze Grey. This is to provide good protection against rot and moisture and ensure the product is sealed.



Installation and maintenance information.



Linax Brown.



Linax®

Sustainable choice with double wood protection

- Repels moisture
- Long maintenance intervals
- Built to last - 50 year rot protection warranty



BITUS OFFICE UK
UNIT 9 CIRENCESTER OFFICE PARK,
TETBURY ROAD, CIRENCESTER
GL7 6JJ
CONTACT

01959 562181 | SALES@BITUS.CO.UK | INFO@BITUS.COM

ROXX www.roxx.se Print: Åtta45, 2023

Linax Natural weather grey



Linax is perfect for:

- Façade panels
- Decking boards
- Anti-noise fencing
- Windbreaks
- Fencing
- Playgrounds and parks
- Benches and garden furniture



THIS IS BITUS

Simply wooden made.

A leading supplier of sustainable wood products that benefit customers and society.

Bitus wants to increase conscious building with quality renewable materials that last longer. With stylish design, Bitus offers sustainable landscape products, facades and construction materials. With our expertise in wood together with innovation, we want to build our customers' trust.



Wood protection with "extra everything"

Linax is sustainable timber with a double wood protection treatment. After traditional wood preservation, the redwood raw material is boiled in linseed oil under vacuum conditions.

The oil adds a surface tone to the wood which becomes part of the natural beauty of the redwood. At present Bitus offer Linax Natural without added pigment, which is a naturally golden colour when newly produced and over time takes on a natural grey tone. Bitus also offer Linax Brown & Linax Grey which have an additional colour pigment added during the treatment process. Linax Brown & Linax Grey are designed to retain their colour.

Linax uses high quality pine from certified forests as the raw material. By selecting Linax, you get an environmentally friendly and sustainable product that is built to last.



Bitus for the environment.

Bitus operates in Sweden, the UK and the Baltics.

Our raw material comes from responsibly managed forests. We utilise all the raw material during production. What doesn't become planks and boards is used to produce pellets.

We work continuously to reduce our climate footprint, among other things by gradually switching to the latest technology and actively influencing our subcontractors.



Linax® – double wood protection treatment

Steps in Linax treatment

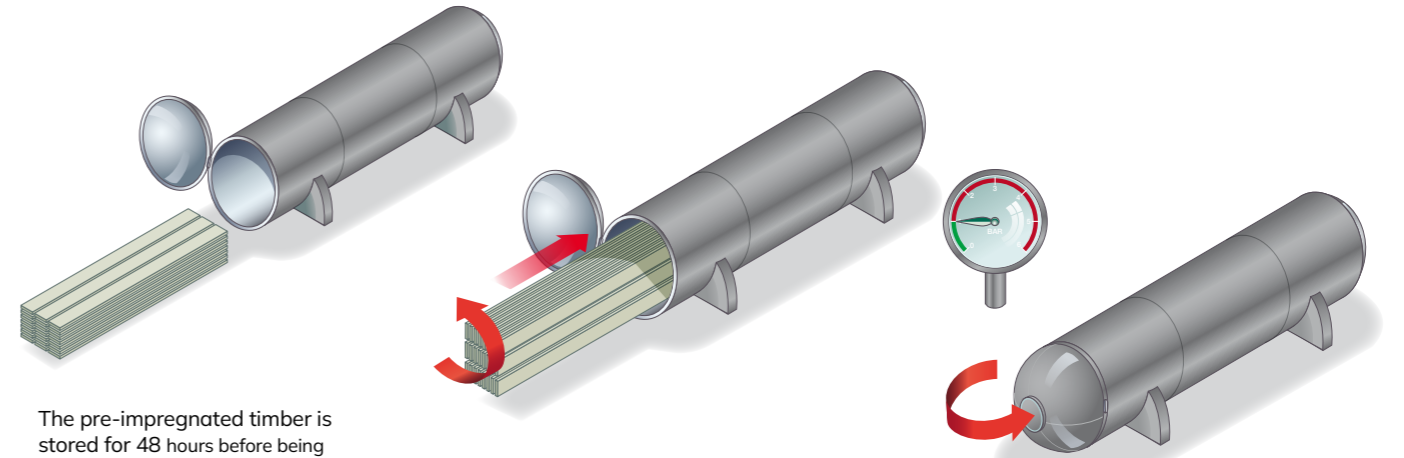

The pre-impregnated timber is stored for 48 hours before being placed in the tube.

The timber is rotated 90 degrees so that the oil can access all parts.

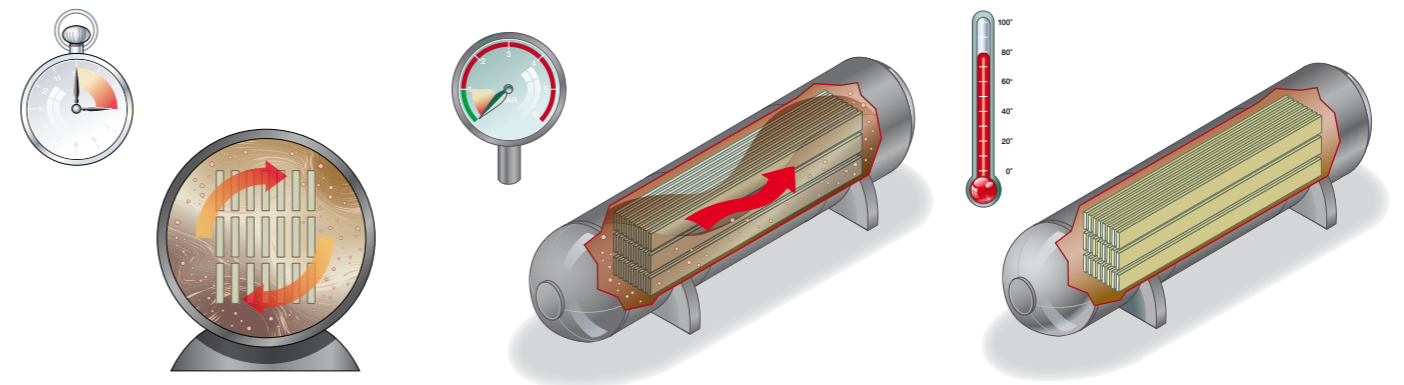

Hot linseed oil, which can be uncoloured or coloured, is added and the treatment is carried out under vacuum conditions.

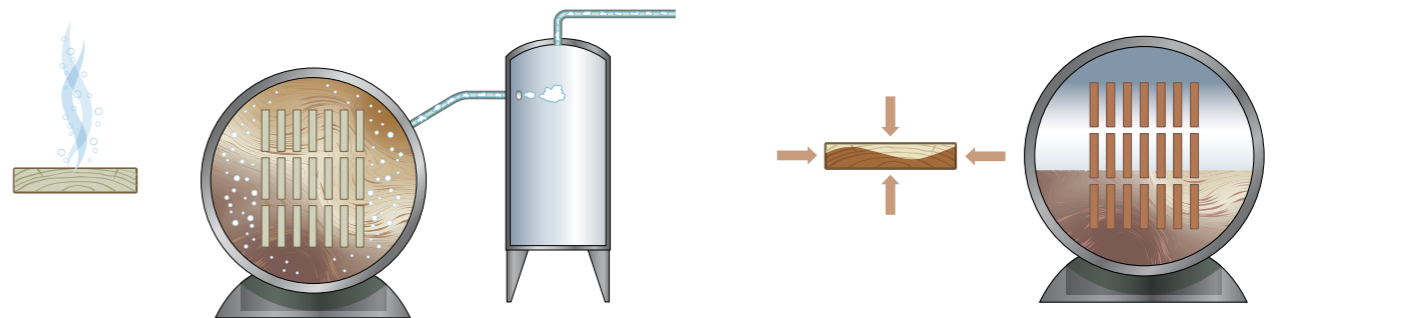

The water vapour is captured in a condenser, much like a tumble dryer.

The water in the wood evaporates and becomes more susceptible to the oil treatment. This is a very gentle drying process that minimises cracking.

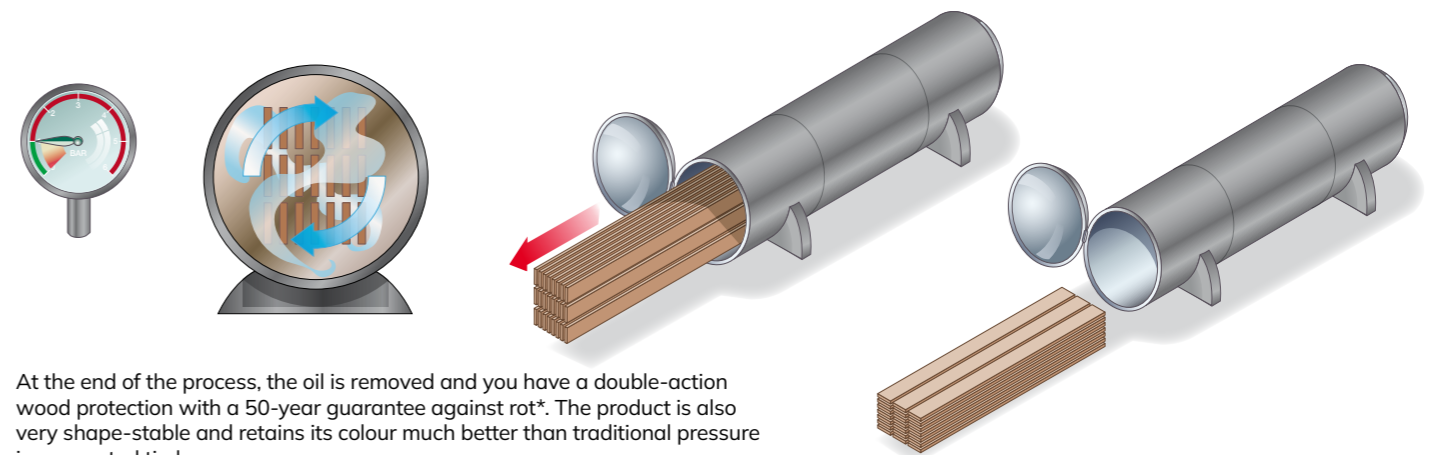

At the end of the process, the oil is removed and you have a double-action wood protection with a 50-year guarantee against rot*. The product is also very shape-stable and retains its colour much better than traditional pressure impregnated timber.

* For the full guarantee, see www.bitus.se

Here's how it works.